

INDEX	PART/DRAWING	DESCRIPTION	QTY
1	P1641G	ACP SENTRY BARRIER MEDIAN POST	2
2	FW001	ACP SENTRY WASHER	4
3	F1002	M16x32 SPLICE BOLT AND NUT FOR RAIL CONNECTION	16
4	F1640	M16x50 POST BOLT AND OVERSIZED NUT	4
5	W100G	4.0M STANDARD W-BEAM	2

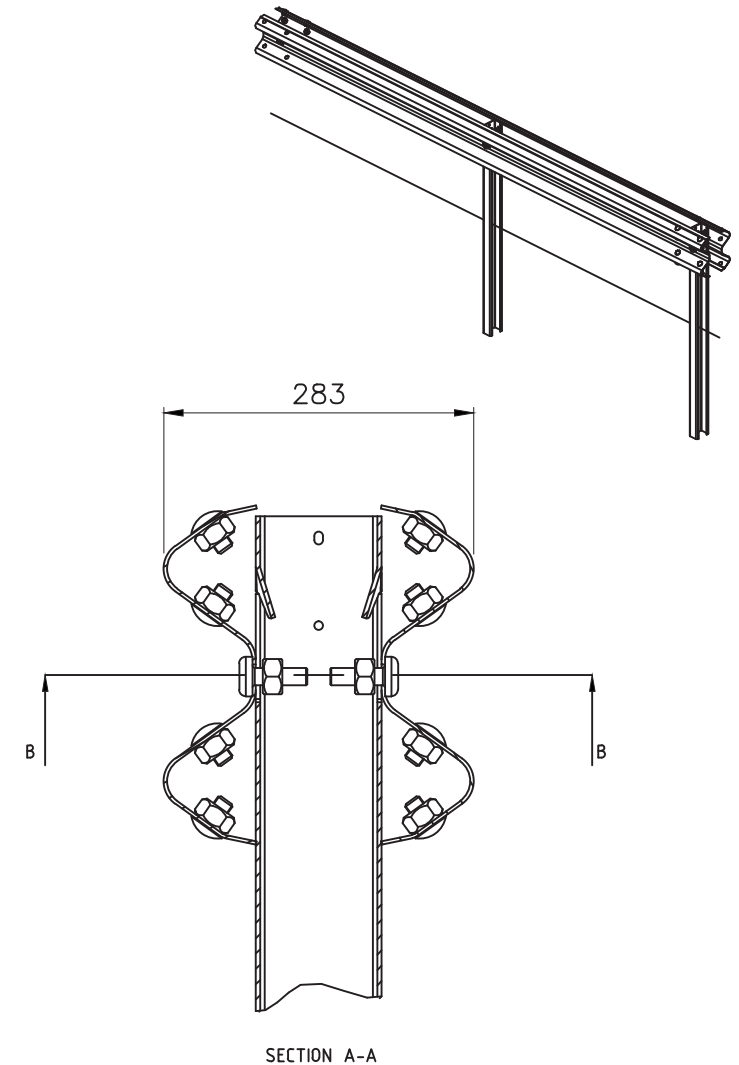
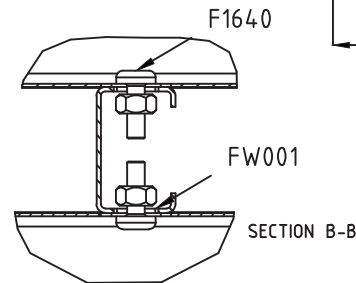
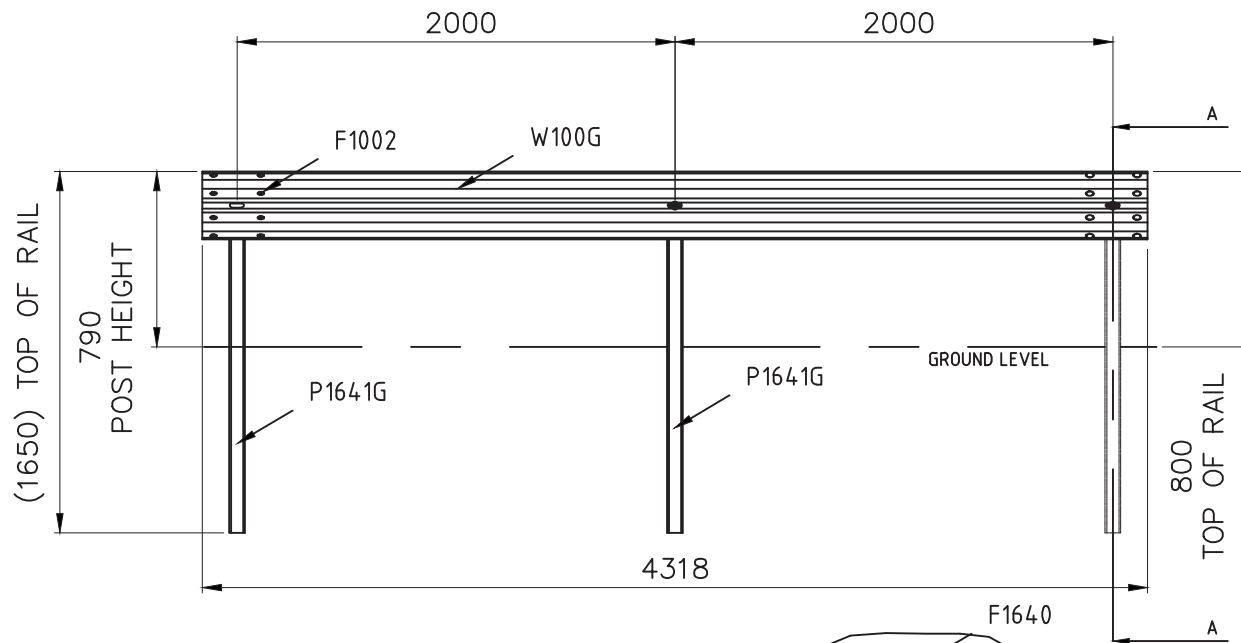

Australian Construction Products Pty Ltd
 339 Horsley Road Milperra NSW 2214
 P.O. Box 565 Panania NSW 2213
 Tel: +61 2 9772 4172 Fax: +61 2 9792 6272

TOLERANCES

Whole Numbers ± 2
 One Decimal Place ± 0.05
 Bend Angle : ± 2
 Straightness : 1.5per1500

Scale: N.T.S.

CLIENT

MATERIAL
 STEEL TO AS/NZS 1594

FINISH
 PRETREATMENT TO AS 1627
 HOT DIP GALVANISE TO AS/NZS 4680

ITEM
 ACP SENTRY MEDIAN BARRIER W BEAM SYSTEM

DRAWING NUMBER

GA089

DRAWN E.A.	CHECKED	APPROVED
---------------	---------	----------

REV	DESCRIPTION	APPD	DATE
A	ORIGINAL ISSUE	E.A.	17.05.18