

ISO EXPLODED VIEW
SCALE 1:10

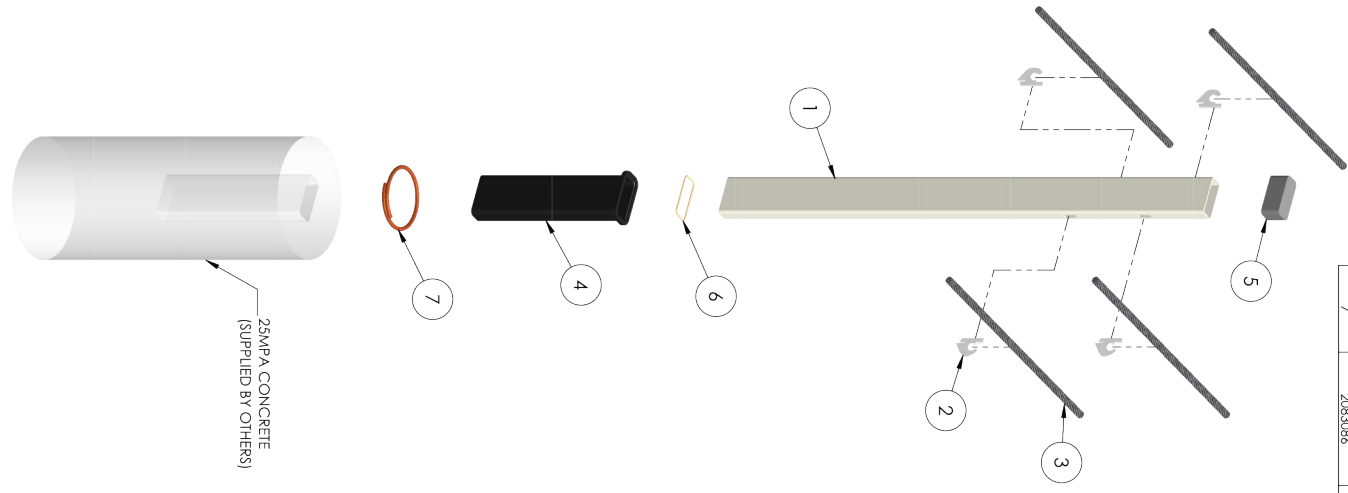

ELEVATION VIEW
SCALE 1:6

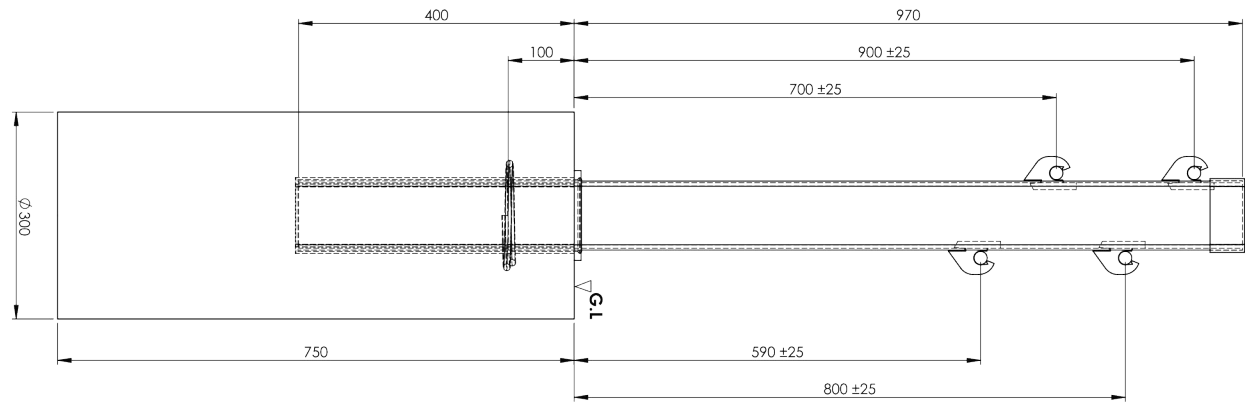

ITEM NO.	PART NO.	DESCRIPTION	QTY.	WEIGHT FA.	DWG NO.
1	20891315LM-A	SL WIRE ROPE LINEPOST 1370mm WHITE - 4 SLOTS	1	7	FX747-A-1
2	2110162SLM	SL WIRE ROPE HALF TIE 8mm ALUMINIUM	4	0.04	FX747-2
3	2200096SLM	SL WIRE ROPE 19mm DIA.	AS REQUIRED		FX747-4
4	2089070SLM	SL WIRE ROPE POST SOCKET	1	0.37	FX747-4
5	20893072SLM	SL WIRE ROPE LINEPOST CAP	1	0.07	FX747-3
6	20893073SLM	SL WIRE ROPE LINEPOST O-RING 5mm	1	0.01	FX747-5
7	20893086	SL WIRE ROPE REBAR RING SMOOTH	1	0.34	



Australian Construction Products Pty Ltd
339 Horsley Road Milperra NSW 2214
P.O. Box 565 Panania NSW 2213
Tel: +61 2 9772 4172 Fax: +61 2 9792 6272

TOLERANCES
Whole Numbers ± 2
One Decimal Place ± 0.05
Bend Angle : ± 2
Straightness : $1.5 \text{ per } 1500$
Scale: N.T.S.

CLIENT
MATERIAL
STEEL TO AS/NZS 1594
FINISH
PRETREATMENT TO AS 1627
HOT DIP GALVANISE TO AS/NZS 4680

ITEM SENTRYLINE-M WIRE ROPE STANDARD
ASSEMBLY WHITE - 4 SLOTS
DRAWING NUMBER
FX754A
DRAWN E.A. CHECKED APPROVED

REV	DESCRIPTION	APPD	DATE
A	ORIGINAL ISSUE	EA	11.06.20