

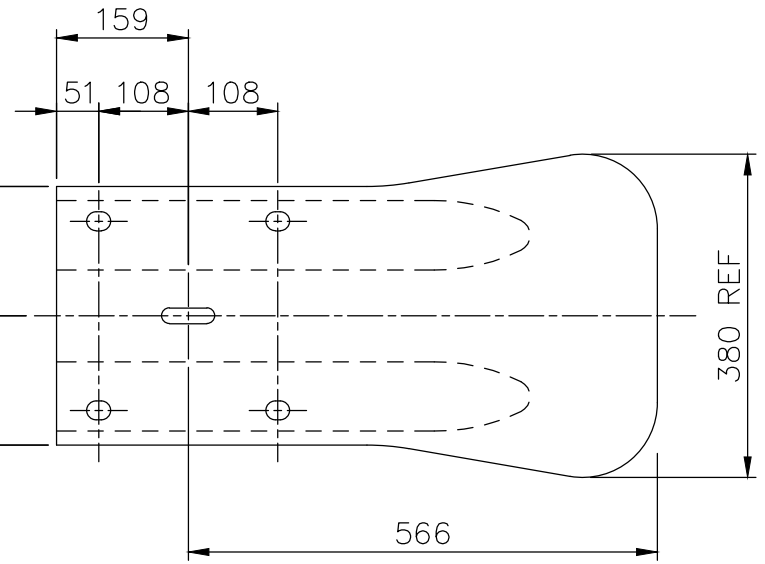

BLANK W507B

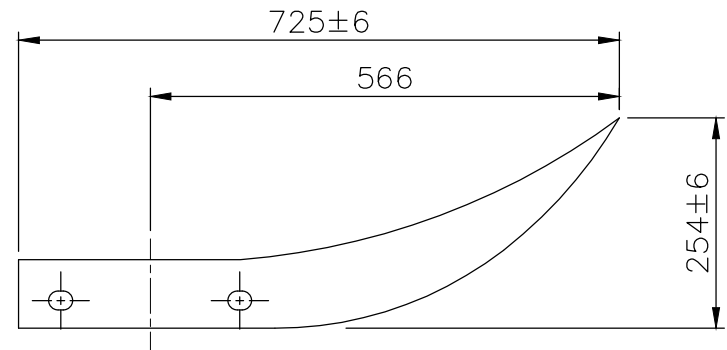

- NOTES:
1. MATERIAL THICKNESS $\pm 0.21\text{mm}$
 2. HOLE DIAMETER $\pm 0.4\text{mm}$

| REV | DESCRIPTION | APPD | DATE |
|-----|----------------|------|----------|
| B | FINISH REVISED | L.B. | 28.01.04 |
| A | ORIGINAL ISSUE | L.B. | 01.03.02 |



Australian Construction Products Pty Ltd

 329 Horsley Road Milperra NSW 2214

 P.O. Box 342 Panania NSW 2213

 Tel: +61 2 9772 4172 Fax: +61 2 9792 6272

A Subsidiary of the Southern Steel Group Pty Ltd

| |
|------------------------------|
| TOLERANCES |
| Whole Numbers ± 2 |
| One Decimal Place ± 0.05 |
| Bend Angle : ± 2 |
| Straightness : 1.5per1500 |
| Scale: |

| |
|--------------------------------------|
| CLIENT |
| MATERIAL |
| 2.7mm BMT HA350 STEEL TO AS/NZS 1594 |
| FINISH |
| PRETREATMENT TO AS 1627 |
| HOT DIP GALVANISE TO AS/NZS 4680 |

| | | |
|-------------------------------|---------|----------|
| ITEM FISHTAIL TERMINAL 4 HOLE | | |
| DRAWING NUMBER | | |
| W507G | | |
| DRAWN | CHECKED | APPROVED |
| W.C | R.T | |