

ITEM	PART NUMBER	DESCRIPTION	QTY
1	UTGAG	SOIL ANCHOR, GALVANIZED	1
2	UTGSG	GROUNDSTRUT, GALVANIZED	1
3	MAXHDG	IMPACT HEAD INCLUDING FRICTION PLATE/BOLTS	1
4	MAXP1G	MAXTENSION POST 1	1
5	MAXTSSG	TSS PANEL, GALVANIZED	1
6	MAXISSG	ISS PANEL, GALVANIZED	1
7	MAXRSSG	RSS PLATE, GALVANIZED	1
8	MAXTL2CAG	CABLE ASSEMBLY	2
9	MAXYN	MAX YELLOW NOSE	1
10	UTLPG	LINE POST	4
11	W122G	W-BEAM 3.81m MAXTENSION W BEAM	2
12	B090534	W-BEAM COMPOSITE BLOCKOUT	4
13	W113G	W-BEAM 1.0 meter RAIL	1
14	BSI-1610066-00	TOOTH, GEOMET	1
15	FW903	75X45X5 RECTANGULAR WASHER GALV	1
16	FW923	50x50x3 GALV SQUARE WASHER	1
17	F1012	M16X50mm POST BOLT&NUT	1
18	FW900	M16 WASHER GALV	2
19	F123	M16X200 HEX HEAD BOLT&NUT GALV	1
20	4001116	TOOTH NUT RECESSED 5/8-11	1
21	F174	14-24x32mm TEKSCREW GALV	4
22	X350NC	PLASTIC NUT COVER	17
23	F1002	M16x32MM SPICE BOLT&NUT GALV	40
24	F124	M16x240 CUP HEAD BOLT&NUT GALV	4

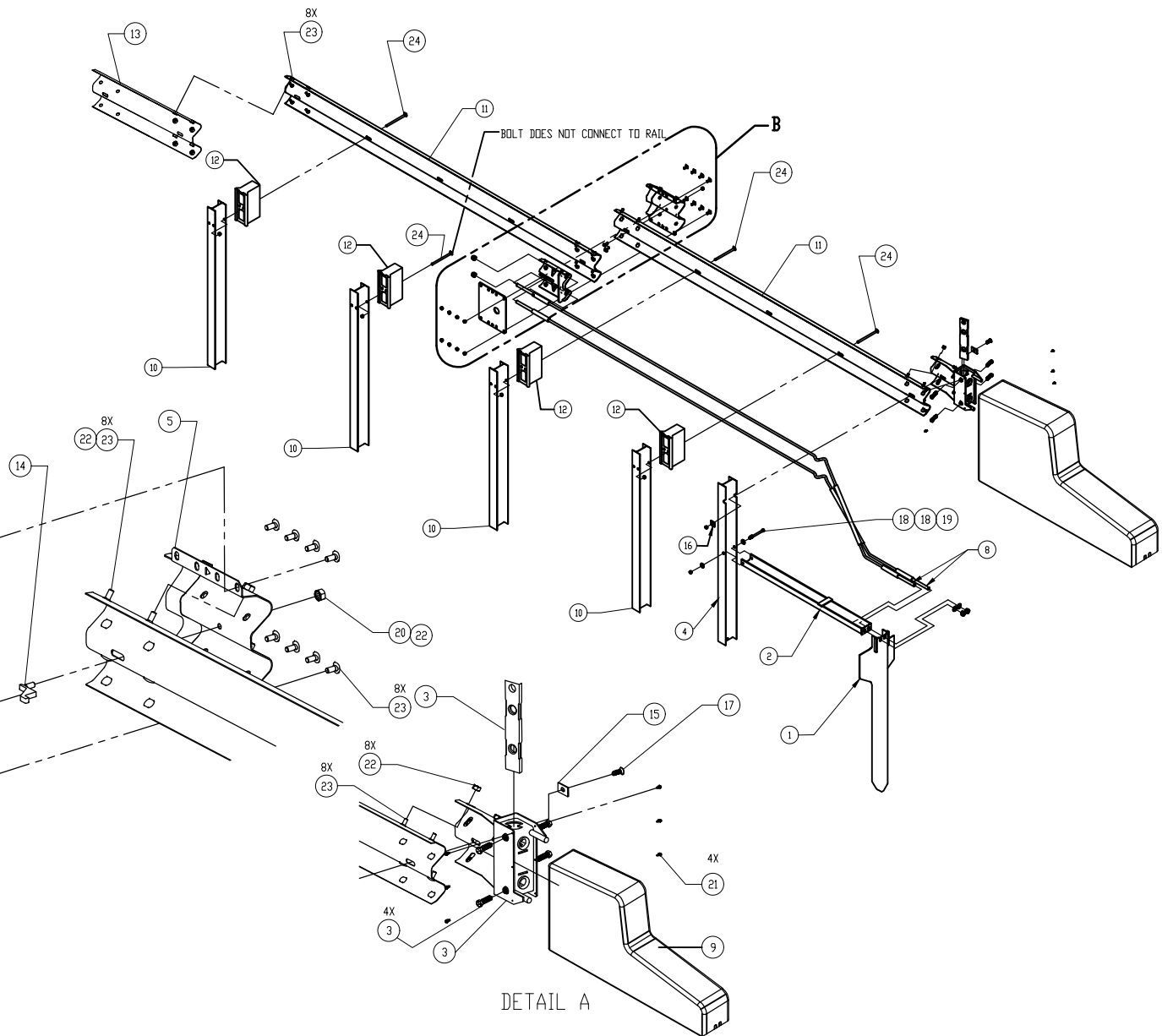

DETAIL B

DETAIL A



Australian Construction Products Pty Ltd
 339 Horsley Road Milperra NSW 2214
 P.O. Box 565 Panania NSW 2213
 Tel: +61 2 9772 4172 Fax: +61 2 9792 6272

TOLERANCES

Whole Numbers ± 2
 One Decimal Place ± 0.05
 Bend Angle : ± 2
 Straightness : $1.5 \text{ per } 1500$

Scale: N.T.S.

CLIENT

MATERIAL
 STEEL TO AS/NZS 1594

FINISH
 PRETREATMENT TO AS 1627
 HOT DIP GALVANISE TO AS/NZS 4680

ITEM
 MAX-TENSION TL-2 TANGENT SYSTEM
 DRAWING 1 OF 2

DRAWING NUMBER
MAXTL2-1

DRAWN E.A.	CHECKED	APPROVED
---------------	---------	----------

REV	DESCRIPTION	APPD	DATE
B	MAXYN USED	EA	3.08.21
A	ORIGINAL ISSUE	EA	23.07.18