

INDEX	PART/DRAWING	DESCRIPTION	QTY
1	P2100G	ACP SENTRY BARRIER POST 2100MM LONG	2
2	FW001	ACP SENTRY WASHER	2
3	F1002	M16x32 SPLICE BOLT AND NUT FOR RAIL CONNECTION	8
4	F1640	M16x40 POST BOLT AND OVERSIZED NUT	2
5	W100G	4.0M STANDARD W-BEAM	1

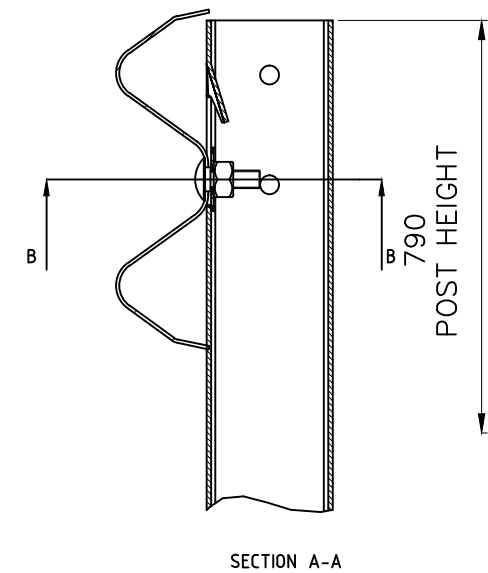
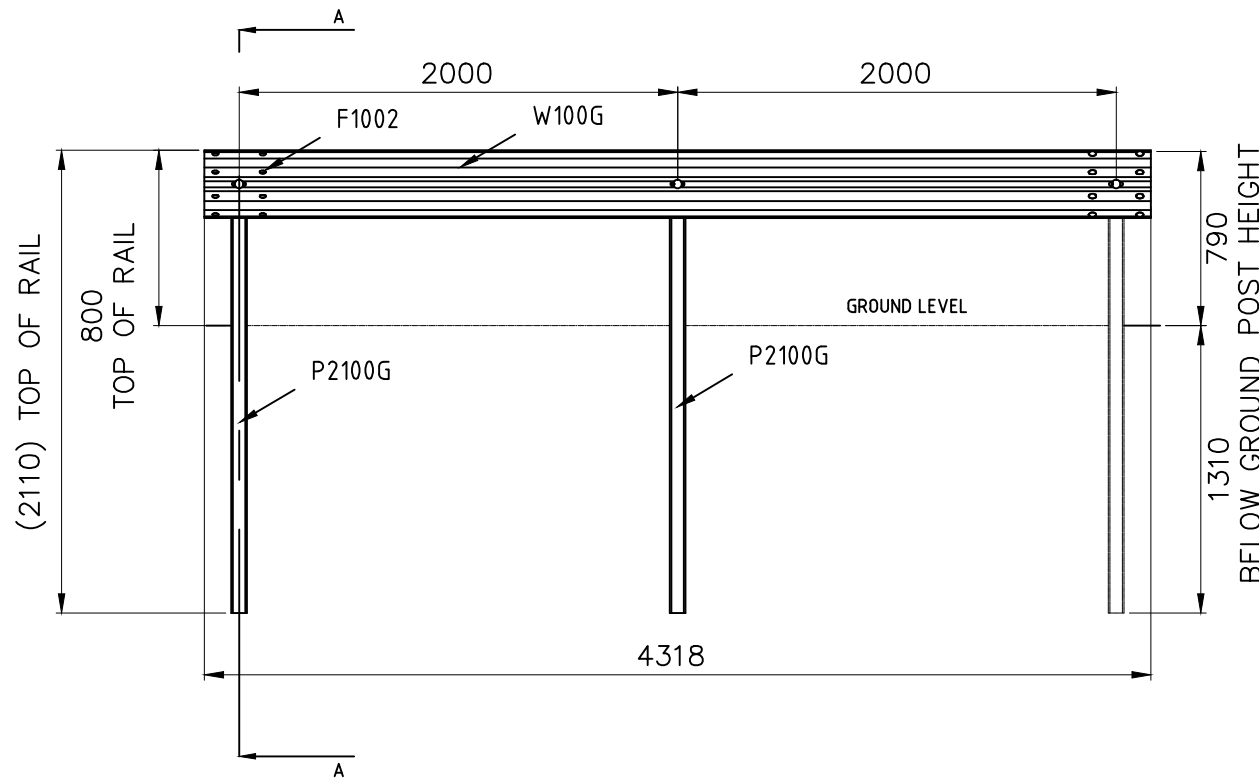
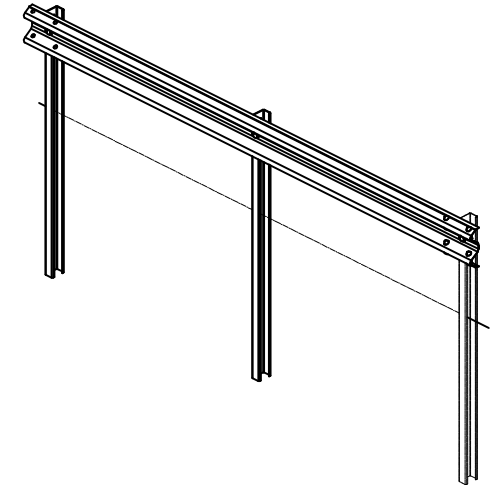
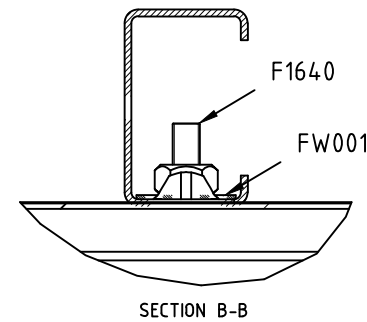

Australian Construction Products Pty Ltd
 339 Horsley Road Milperra NSW 2214
 P.O. Box 565 Panania NSW 2213
 Tel: +61 2 9772 4172 Fax: +61 2 9792 6272

A member of the Fletcher Building Group

TOLERANCES

Whole Numbers ± 2
 One Decimal Place ± 0.05
 Bend Angle : ± 2
 Straightness : 1.5per1500

Scale: N.T.S.

CLIENT

MATERIAL
 STEEL TO AS/NZS 1594

FINISH

PRETREATMENT TO AS 1627
 HOT DIP GALVANISE TO AS/NZS 4680

ITEM

ACP SENTRY BARRIER W BEAM SYSTEM
 SUITABLE FOR 2H:1V B.SLOPE & WEAK SOIL

DRAWING NUMBER

GA087L

DRAWN
 W.R.

CHECKED
 E.A.

APPROVED

REV	DESCRIPTION	APPD	DATE
A	ORIGINAL ISSUE	W.R.	10.09.19