

INDEX	PART/DRAWING	DESCRIPTION	QTY
1	P1640G	ACP SENTRY BARRIER POST	2
2	FW001	ACP SENTRY WASHER	2
3	F1002	M16x32 SPLICE BOLT AND NUT FOR RAIL CONNECTION	8
4	F1022	M16x50 POST BOLT AND OVERSIZED NUT	2
5	W100G	4.0M STANDARD W-BEAM	1

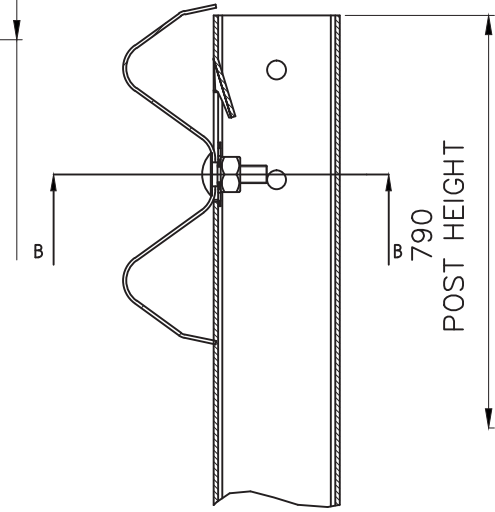

SECTION A-A

SECTION B-B

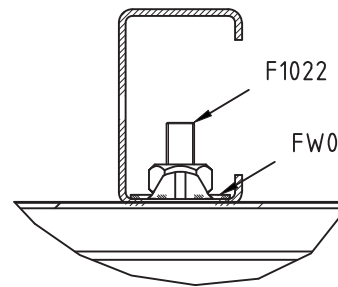
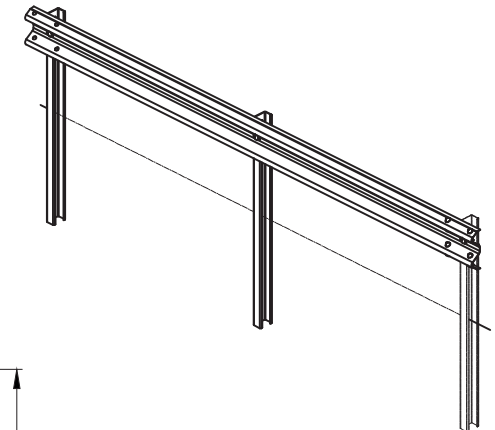
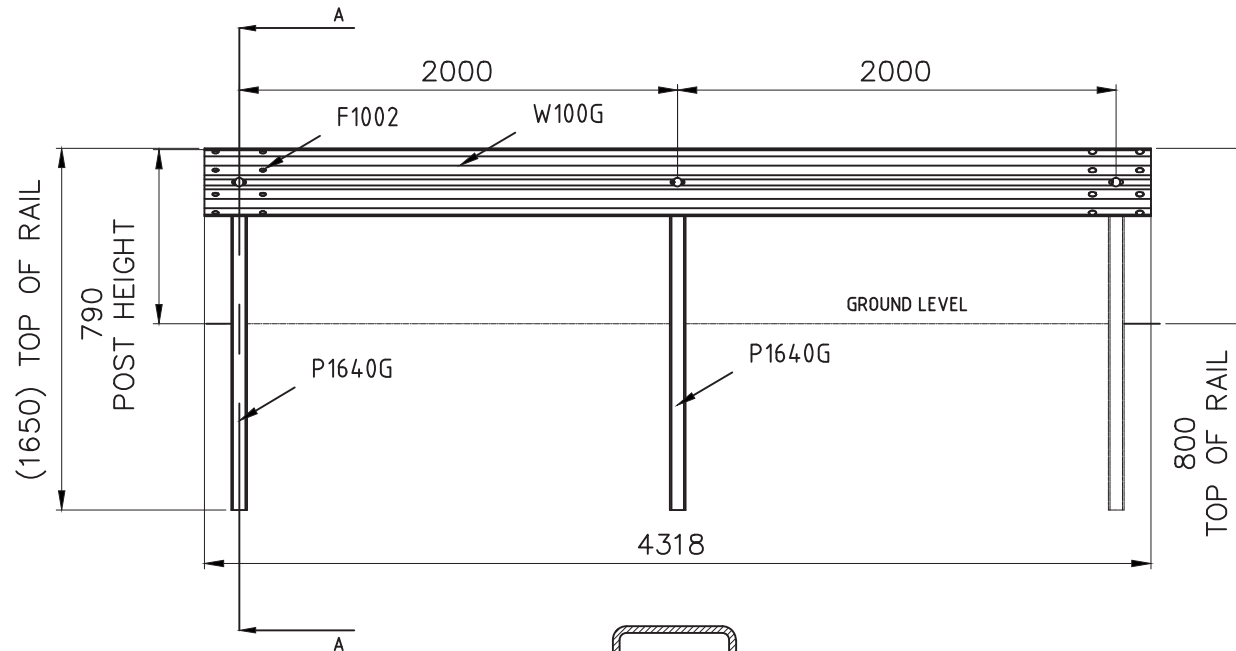

Australian Construction Products Pty Ltd
 339 Horsley Road Milperra NSW 2214
 P.O. Box 565 Panania NSW 2213
 Tel: +61 2 9772 4172 Fax: +61 2 9792 6272

TOLERANCES
 Whole Numbers ± 2
 One Decimal Place ± 0.05
 Bend Angle : ± 2
 Straightness : 1.5per1500
 Scale: N.T.S.

CLIENT
 MATERIAL
 STEEL TO AS/NZS 1594
 FINISH
 PRETREATMENT TO AS 1627
 HOT DIP GALVANISE TO AS/NZS 4680

ITEM
 ACP SENTRY BARRIER W BEAM SYSTEM
 DRAWING NUMBER
GA087
 DRAWN
 E.A.
 CHECKED
 APPROVED

REV	DESCRIPTION	APPD	DATE
A	ORIGINAL ISSUE	E.A.	12.04.16